

Installation Guide

Mounting

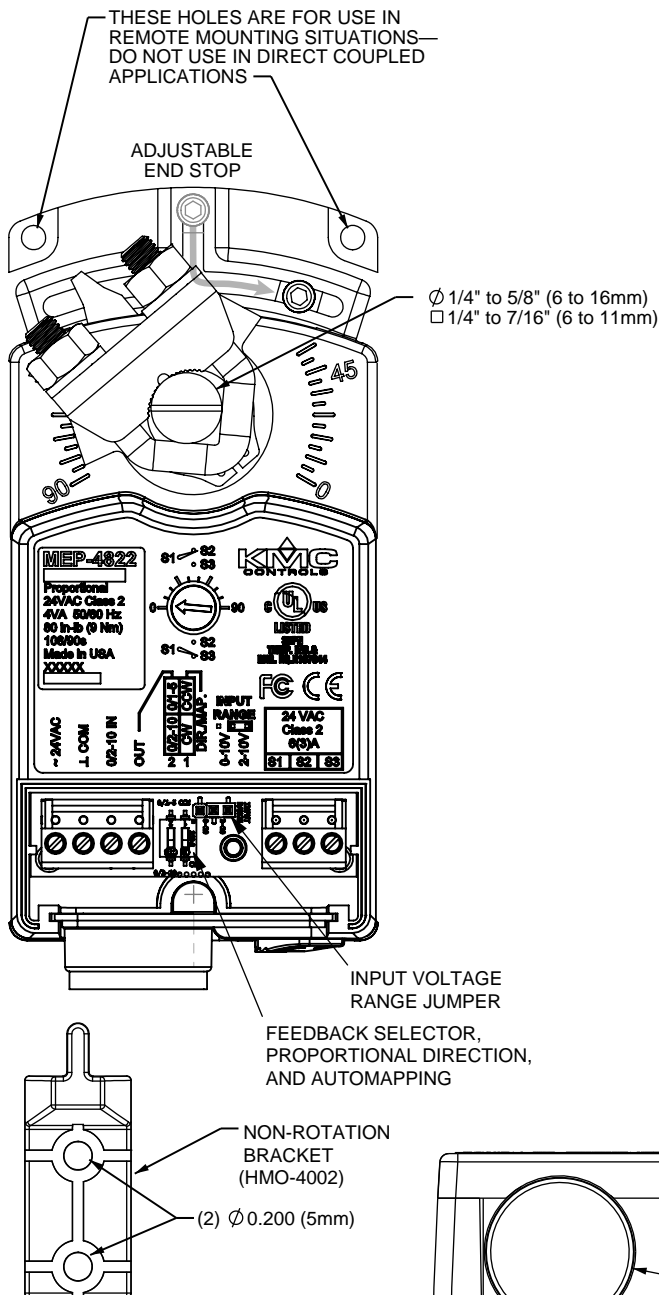

Illustration 1—Overview
(Direct-Coupled Mounting)

1. Ensure the damper can move freely through its entire range of motion, and fix any binding before installing the actuator. Turn the damper blade to its fully closed position.
2. Press (to the right) and hold the gear disengagement lever (see Illustration 1), rotate the actuator to the fully closed position, and release the lever.

NOTE: Depending on the damper-seal design, backing the actuator off its stop approximately 5° may provide tight damper shut-off.

3. Align the actuator and slide it onto the shaft.
4. Leaving a gap between the actuator and mounting surface to prevent any binding, finger-tighten the nuts on the V-bolt.
5. Insert the non-rotation bracket (HMO-4002 supplied or HMO-4001 "T" bracket available separately) into the slot at the base of the actuator. (See Illustration 1).
6. Secure the non-rotation bracket with two (2) #8 or #10 self-tapping screws.
7. Evenly tighten the V-bolt nuts 30–35 in-lb. on MEP-4000s or 60–70 in-lb. on MEP-4800s.
8. If desired, use a 7/64-inch hex key wrench to loosen and position the end-stop screw.

NOTE: The two holes at the top of the actuator are **NOT** for use in direct-coupled applications. They are for remote mounting, such as with the optional HLO-4001 Crank Arm Kit (see the [MEP-4000/4800 Series Data Sheet](#)).

Wiring

NOTE: Before Jan. 2014, MEP-40x2/48x2 **proportional** models had **0–10 VDC inputs** and **0–5 or 0–10 VDC feedback** (only). From 2014 through July 2015, they had **2–10 VDC inputs** and **1–5 or 2–10 VDC** (only) feedback instead. Starting in August 2015, **all** these options were available and selectable via a jumper and slide switch.

MEP-4003 Only

NOTE: The MEP-4003's terminals are not enclosed inside the case as the other models are.

1. Route the cable through the strain relief molded in the lower left of the case. (See Illustration 2.)
2. Connect the wires to the terminal block.

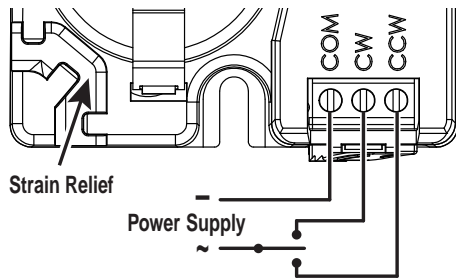

Illustration 2—MEP-4003 (Only) Wiring

All Except MEP-4003

1. Loosen the screw on the tethered access cover and remove the cover.
2. Slide the conduit fitting plate out.
3. Using a utility knife or drill, cut the red plug to accept wiring or replace the plug with an application-specific fitting.

NOTE: The red plug (or similar fitting) protects internal components from debris, helping to ensure long actuator life.

4. Thread wires through the plugged opening and connect to the terminal block. (See Illustrations 3 through 5.)

NOTE: For your convenience, the wiring terminal block is removable.

5. Connect and adjust the auxiliary switch if required (MEP-4x2x only). See [Auxiliary Switch \(4x2x\) on page 4](#).
6. Reinstall the terminal block on the pins (if removed) and the conduit fitting plate.
7. For MEP-4xx2 (proportional) models, adjust the input range, feedback voltage, rotation direction,

and auto-mapping range reset as needed. See Illustration 5 and [Proportional \(MEP-4xx2\) Models Setup on page 3](#).

8. For MEP-4xx1/4x13s, adjust rotation direction switch if needed (see Illustration 3 and 4).
9. Reinstall the tethered cover and tighten the screw.

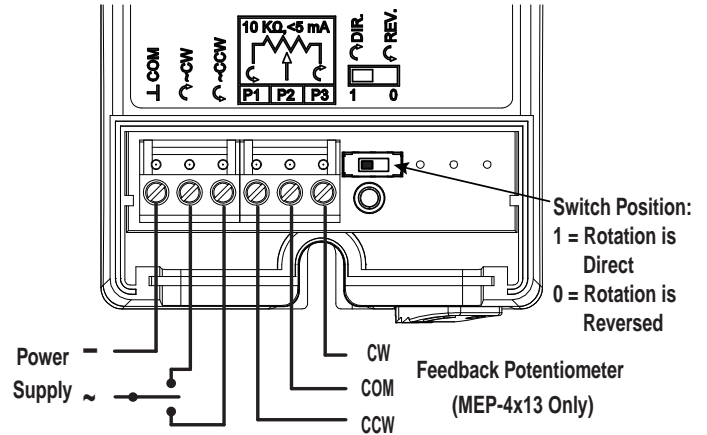

Illustration 3—MEP-4xx1/4x13 TRI-STATE Wiring

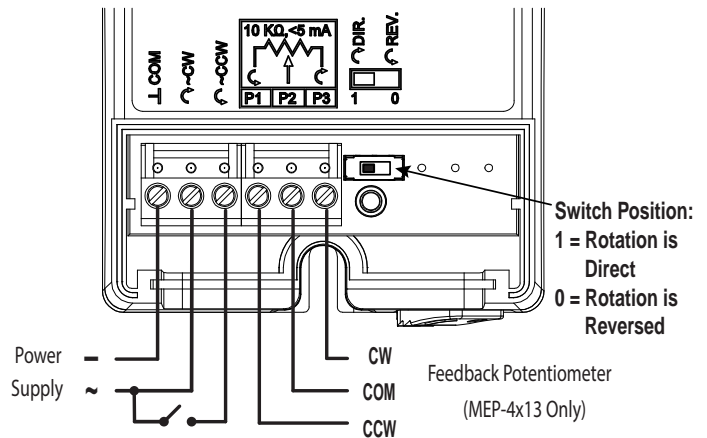

Illustration 4—MEP-4xx1/4x13 2-POSITION (3-Wire) Wiring

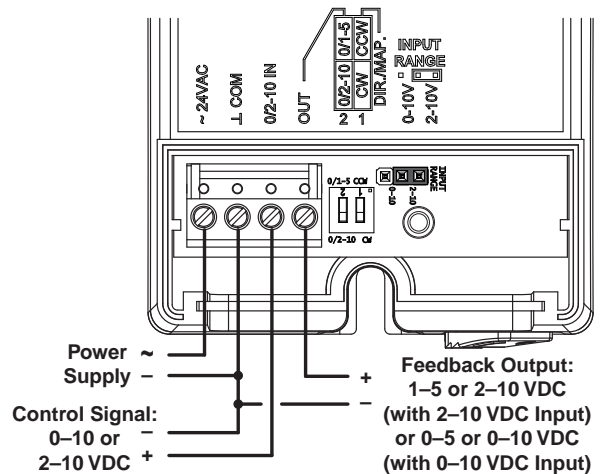
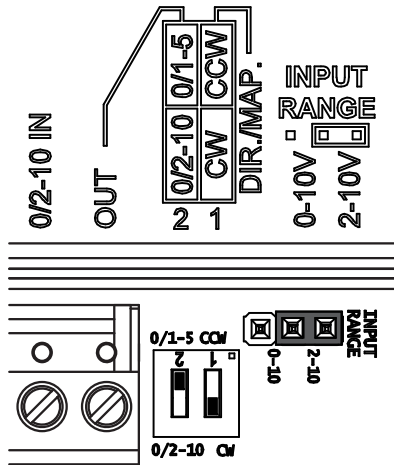

Illustration 5—MEP-4xx2 Proportional Wiring

Proportional (MEP-4xx2) Models Setup

Proportional actuators are shipped with factory settings of 2–10 VDC input, 1–5 VDC feedback voltage, and CW movement with increasing voltage. To change any settings, access the selector switches and jumper (see Illustrations 5 and 6) by loosening the screws on the conduit fitting and lifting up to remove the fitting.

1. Select actuator rotation with the **Direction** switch.
2. Use the **Input Range** jumper to select either 0–10 or 2–10 for the VDC input range. This also sets the starting point for the feedback voltage (e.g., 2–10 VDC input provides a corresponding feedback voltage of either 2–10 or 1–5 VDC). Select the desired feedback range with the **Feedback** switch.



Switch	Feedback	Direction*
Up	0/1–5 VDC	CCW
Down	0/2–10 VDC	CW

Illustration 6—Feedback/Direction/Mapping Selectors

*NOTE: The Direction switch has two functions:

1. It determines the direction to rotate (CW or CCW) with increasing voltage and is factory set in the CW position (down). To change, remove power before flipping the switch up to the CCW position. Removing power prevents initiation of the auto-mapping feature.
2. It initiates the auto-mapping feature. (See description below.) This feature is initiated only by cycling the switch with power applied to the unit. The auto-mapping feature will NOT begin if the switch position is changed with power removed or in the event of a power failure.

MEP-4xx2 models also offer a **actuator/signal range reset program (auto-mapping)** feature that reassigns the full 0/2–10 VDC input signal scale over a reduced stroke range for more precise control.

NOTE: The auto-mapping feature works best for ranges that are more than about 45°.

To set the auto-mapping:

1. If desired, use a 7/64-inch hex key wrench to loosen and position the end-stop screw.
2. With power applied to the actuator, flip the Direction switch (from its required CW or CCW increasing voltage direction) to start the reset mode. The actuator will first move to the CCW limit. The complete reset process will take approximately four minutes.
3. Return the Direction switch to the required increasing voltage direction before the reset finishes. The reset process is complete after the actuator has moved to the CW limit and has begun to position normally.
4. Verify that the actuator travels completely across the new range.

For example, after completing the auto-mapping program, the **new actuator stroke is 0–80°**:

- With a 0–10 VDC input, a 5 VDC input signal (halfway between 0–10 VDC) will drive the actuator to the 40° position (50% of its adjusted range) and the feedback voltage will be 2.5 VDC if the Feedback switch is set at the 0–5 VDC position or 5 VDC if the Feedback switch is set at 0–10 VDC.
- With a 2–10 VDC input, a 6 VDC input signal (halfway between 2–10 VDC) will drive the actuator to the 40° position (50% of its adjusted range) and the feedback voltage will be 3 VDC if the Feedback switch is set at the 1–5 VDC position or 6 VDC if the Feedback switch is set at 2–10 VDC.

NOTE: After automapping, the feedback range will be equally affected.

NOTE: For more information (including adjustments, accessories, troubleshooting, torque selection, and links to sample applications), see the [MEP-4xxx Applications Guide on the KMC web site](#).

Auxiliary Switch (4x2x)

In MEP-4x2x models, the adjustable auxiliary SPDT switch can be set to trip anywhere between 0° (full CW rotation position) and 90° (full CCW). To adjust the auxiliary switch position, two different methods can be followed. (Method 2 is generally slightly more precise.)

Method 1

1. While pressing the gear disengagement lever (see Illustration 1), **rotate the actuator to the full clockwise position (0°)**.
2. Using a small, flat-bade screwdriver, **adjust the rotary dial to the desired number of degrees** (as shown on the dial) at which the switch should trip. For example, if the switch is set to trip at 45° (dial halfway between 0° and 90° when actuator is at full CW position), then S1 is connected to S2 from 0° to 45°, and S1 is connected to S3 from 45° to 90°. As the actuator rotates, the switch dial arrow will point to the current switch position (S1 connected to S2 vs. S1 connected to S3).
3. Connect the auxiliary unit to the terminal block (see Illustration 7).

Method 2

1. While pressing the gear disengagement lever, **rotate the actuator to the point where the auxiliary switch should trip**.
2. Using a small, flat-bade screwdriver, **adjust the rotary dial to "0"**. For example, if the switch is set to trip (dial at "0") when the actuator rotation position is at 45°, then S1 is connected to S3 from 0° to 45°, and S1 is connected to S2 from 45° to 90°. As the actuator rotates, the switch dial arrow will point to the current switch position (S1 connected to S2 vs. S1 connected to S3).
3. Connect the auxiliary unit to the terminal block (see Illustration 7).

NOTE: The SPDT switch is rated for 6 A with resistive load or 3 A with motor load @ 250 VAC.

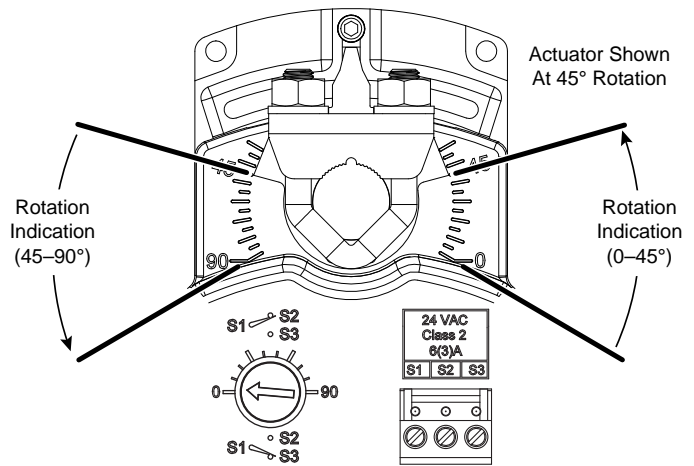

Illustration 7—Auxiliary Switch Dial and Terminal Block

Maintenance

No routine maintenance is required. Careful installation will also ensure long term reliability and performance.

More Information

For specifications and other information, see the [MEP-4000/4800 Series Data Sheet](#) on the [KMC web site](#).

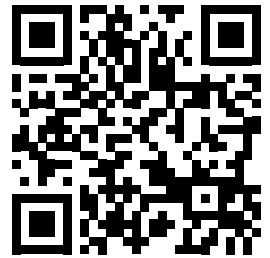

For adjustments, accessories, troubleshooting, torque selection, links to sample applications, and other information, see the [MEP-4xxx Applications Guide](#) on the [KMC web site](#).

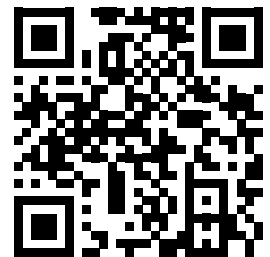

KMC Controls, Inc.
19476 Industrial Drive
New Paris, IN 46553
574.831.5250
www.kmccontrols.com
info@kmccontrols.com